

HARDWARE ISSUES MIGRATING LEGACY TPS TO A NEW TESTER

Hal Wehrman
The Boeing Company
20403 - 68th Avenue S Bldg 18-61,
Kent, WA 98032
Phone (253) 657-0017
Harold.R.Wehrman@boeing.com

Abstract - In the late 1970's The Boeing Company designed and developed the 757 and 767 commercial airplanes. To facilitate production and return-to-service testing of the complex avionics used in these airplanes, the company contracted with Hewlett Packard Co. to develop an Automated Test System (ATS) used by our factory employees and airline customers. Hewlett Packard's ATS/1000 product line was chosen as a core test system and the result was the Boeing ATS-182 test system. In the mid 1990's a Boeing developed ATS-195 for the 777 commercial airplane supported production and return to service testing of 777 avionics.

This paper discusses Boeing solutions for migrating Test Program Set (TPS) to a new ATS. The paper combines test capability of two different legacy test systems into one new ATS design. These ATS are used for TPS development, production and return-to-service testing of complex avionics for commercial airplanes. Due to the increasing cost of operating the legacy test systems and the availability of obsolescence-tolerant instruments, and instrument drivers the business case justified the need to migrate to a new ATS.

The new ATS uses a revolutionary dual tiered VXI interface that maintains signal integrity by reducing instrument and switching system cable lengths. A cost affective approach to use the legacy Test Unit Adapters (TUA) on the new ATS is achieved by using an "adapter-to-adapter." An innovative Printed Wiring Board (PWB) design is used within the adapter-to-adapter to reduce manufacturing costs and minimize variability. A ¼-inch thick, 30 layers PWB is used to minimize structural deflection due to the high pin count used for the dual tier interface and to provide

proper signal separation. Challenges in creating proper impedance matching and signal grounding while maintaining the structural aspects of this PWB are discussed in this paper.

Difficulties in finding commercial-off-the-shelf (COTS) solutions to match legacy switching systems and instruments are discussed.

This paper discusses hardware challenges and solutions for these areas of common interest for legacy TPS migration to a new ATS as well as support and variability issues with legacy ATE.

BACKGROUND

ATS-182

The ATS-182, developed in 1970, has faced ever-increasing maintainability issues. Several of the internal instruments are becoming difficult to repair due to a lack of parts. Due to the maintainability issues, creating an alternative to the ATS-182 became increasingly desirable.

The TPS software on the ATS-182 was largely BASIC, with a few written in FORTRAN. The mixture of these TPSs was 340 BASIC and 25 FORTRAN. The huge number of BASIC TPSs made it ineffective from a cost standpoint to rewrite these TPSs. Supporting these, TPSs were 50 Integrated Test Adapters (ITAs) and 150 loadboards designed for use on the ATS-182. Redesigning and building new ITAs and loadboards proved to be very expensive. As a result, rehost of the BASIC TPSs and ITAs was the most cost effective solution. The decision on FORTRAN TPS migration remains in the future.

There are currently two receivers supporting ITAs and loadboards on the ATS-182. Figure 1 shows the location of the main receiver and the Digital Test Unit (DTU) receiver.

The main receiver is an AMP pin and paddle single tier receiver.

The DTU receiver performs functional level test of Single Card Replaceable Units (SRUs).

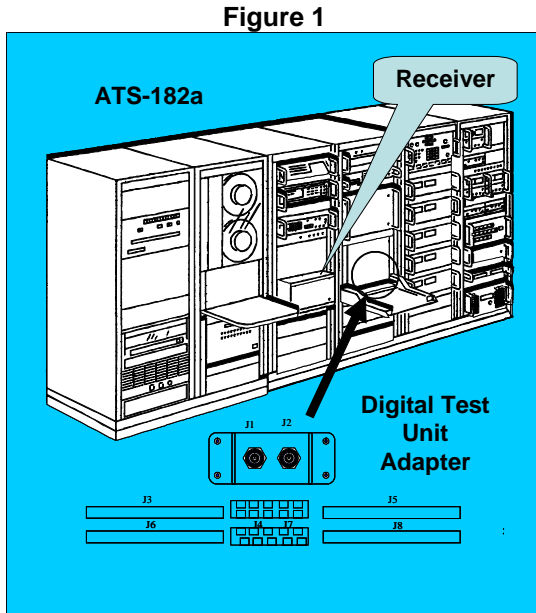

ATS-195

The ATS-195 supports production and return to service for Boeing built 777 LRUs. There were 37 LRUs hosted on the ATS-195. Since both the RF and Video LRUs were coming to the end of production they were removed from the list of LRUs that Boeing agreed to host on the Boeing Common Test System (BCTS), resulting in 31 ATS-195 LRUs rehosted to the BCTS.

The low numbers of LRUs on the ATS-195 did not demonstrate a cost effective solution for reuse of either the software or ITAs. As a result, the decision was made to rehost the 31 LRUs by redesigning all of the LRU tests.

BCTS HIGH LEVEL REQUIREMENTS

High Level Requirements

The following list is a high-level representation of the hardware requirements.

- Modular and Scalable
- Reuse ATS-182 ITAs
- Rehost ATS-195 LRUs
- Ability to use PWB ITA's
- Reduce cabling quantity and length
- High quality measurement paths

BOEING COMMON TEST SET HARDWARE SYSTEM OVERVIEW

Integrated solution

System level integration of hardware for the hardware for the BCTS defined a cohesive design replicating the ATS-182 main receiver and DTU, along with support for ATS-195 TPS rehost, and future hosting of TPSs.

To replicate the ATS-182 receiver and DTU, a system level integration occurs, recreating ATS-182 electrical signal paths. Accomplishment of this integration utilized the following system hardware components:

- Dual tier VXI chassis with integrated dual tier receiver
- Integrated switching
- Main Receiver Adapter to Adapter
- DTU adapter to adapter
- Instruments supporting ATS-182 instrument requirements

These system hardware components are discussed individually, followed by a summary description of how the components work together.

INTEGRATED DUAL TIER CHASSIS

Dual Tier Chassis

The dual tier VXI chassis is a two-tiered chassis supporting VXI modules on each of the tiers. Integrated on the front of the chassis is the receiver for the station. Both tiers of the chassis support VXI modules with integrated funnels and receiver connectors.

Figure 2 shows the dual tier receiver with the integrated receiver.

The receiver frame folds down exposing the VXI modules, funnels, and receiver connectors. This feature allows easy removal of the modules with a significant improvement in maintainability.

The other aspect to note in Figure 2 shows that the receiver frame is flush with the front frame of the test system rack.

Recessed VXI module faces, VXI chassis, and other rack mount instruments are

Figure 2

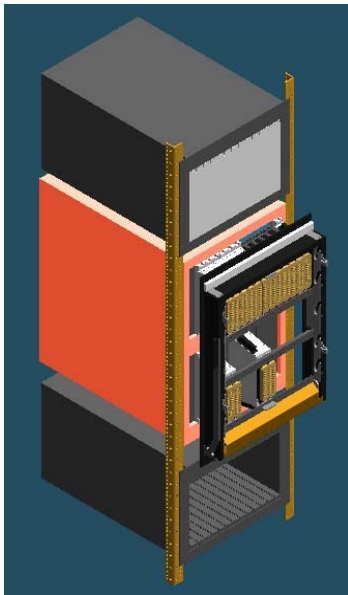
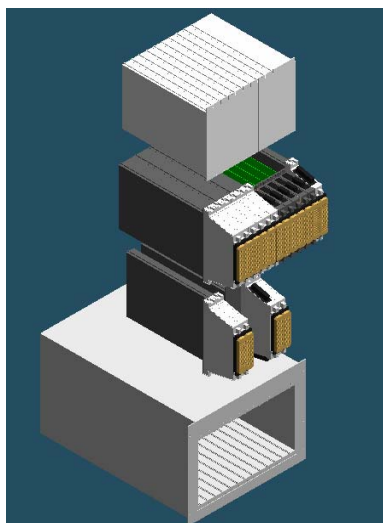

Figure 3



approximately one funnel length behind the face of the station. The rack itself is deeper, with closable doors on the front of the station.

These recessed instruments allow routing of cables across the front of the station to the VXI funnels located in the dual tier receiver. This technique simplified and shortened the routing and length of the station cables.

A traditional design utilizes the lower tier by wiring receiver connectors to the instrument. This often requires cables that have a bend radius to allow the lowering of the receiver. Cable routing from the receiver to the back of the station, and then returning to the front of the station resulted in several feet of cable. Extra connectors in line with the cable facilitate maintenance increasing the quantity of cables. The long cables create long signal paths.

Figure 3 shows the two tiers of the dual tier chassis with the receiver and dual tier chassis removed. The original station design included a VXI chassis above and below the dual tier chassis. The electrical signals from these VXI modules easily route to the funnels in both the top and lower tiers. The dual tier chassis with VXI chassis above and below allows several more instruments access to the receiver through very short and simplified cables to the funnels. Traditional rack mount instruments recessed and placed in the bays left and right of the receiver also allow simplified cable routing along the front of the rack directly to the receiver.

By shortening and simplifying the cables, electrical signal performance improves significantly.

Beyond improved signal performance, is a desire for a modular and scalable system. Scalability comes from the ease of adding new station resources to the BCTS while modularity results in a family of testers with different configurations.

The combination of a large number of available VXI modules with the ability to route directly to the receiver greatly simplifies adding resources to the station. Simplification to the modification process minimizes the impact of adding resources. This simplified process is the key to creating a scalable and modular system

INTEGRATED SWITCHING

The left most funnel on the bottom tier of the dual tier chassis supports high current power to the receiver. To ease maintainability, this funnel receiver has no associated VXI module. Because of the size of wires and cabling and the fact that power supplies connect from the back, the high current power connector reverted to the traditional method. A higher current

switch placed next to the power connector allows easy distribution of power.

The VXI modules in the top tier support

station switching. The large amounts of legacy switching required very dense switching to fit into this small receiver area.

The switching modules on the right side of the top tier support a non-blocking matrix of 192 by 16. These modules

plug into a switching chassis with an integrated analog backplane, which in turn plugs into the VXI chassis. See Figure 4. The analog backplane contains 16 analog channels for the matrix.

A fifth module in the right side of this chassis supports coaxial connectors

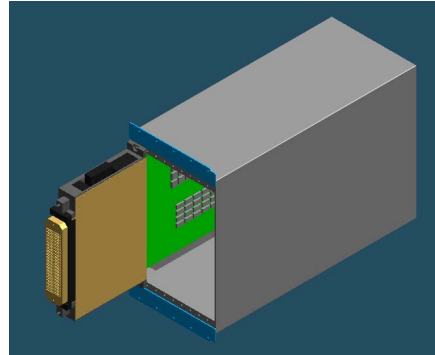

Figure 4

with six high frequency switches. This module also has access to the analog backplane, and supports the Oscilloscope, Digital Multi Meter (DMM), waveform generator, and other coaxial type resources. This module also has switching allowing access to the rear analog channels in the chassis.

Figure 5 is a pictorial representation of one of the four matrix switch modules.

Each module contains 48 matrix channels, divided into three switching sections of 16 each. There are three resource connectors on each matrix-switching module supporting 16 channels each.

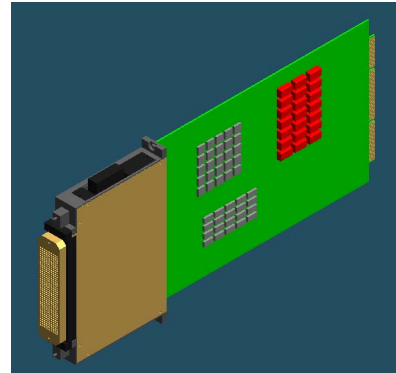

Figure 6

The front-end funnel area of the matrix switch has an integrated switching structure allowing the ATS receiver the ability to connect to the resource or the matrix. See Figure 6. This switching integration supports high signal performance and integration of some of the station resources with the receiver. These resources include a digital test unit, and an analog virtual instrument.

This matrix switch structure along with the receiver adapter to adapter supports the legacy ATS-182 HP matrix structure.

The other switch modules in the top tier include 1 by 8, Single Pole Single Throw (SPST), and Single Pole Double Throw (SPDT) switches.

An adapter developed to measure the resistance of every switching path obtained results to use later in the design. These measured results were compared to sample measurements obtained from the ATS-182.

RECEIVER ADAPTER TO ADAPTER

The next part of the integration of the legacy ATS-182 receiver explores the adapter to adapter. Selection of a PWB approach versus a wired approach reduces manufacturing costs, results in

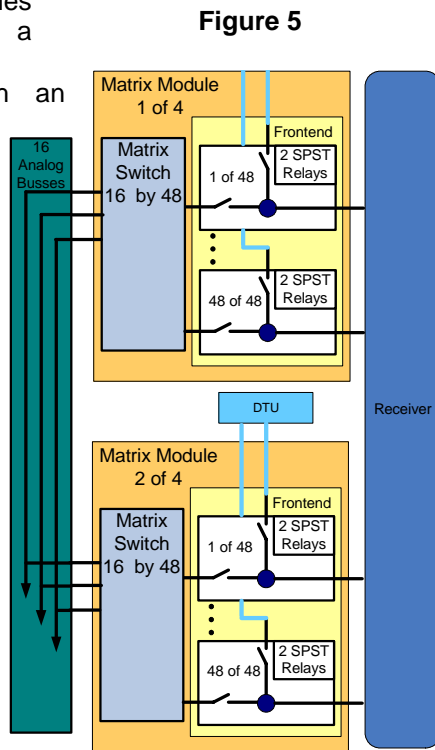

Figure 5

better control of signals, and reduces overall size and weight. To simplify the PWB design, a receiver with blind-mate pogo-pin technology allowed the use of surface pads on the adapter-to-adapter PWB.

Receiver

Because of difficulty of maintaining a reliable connection with pogo pins on the legacy ATS-195, there was a great deal of concern using this technology.

Figure 7

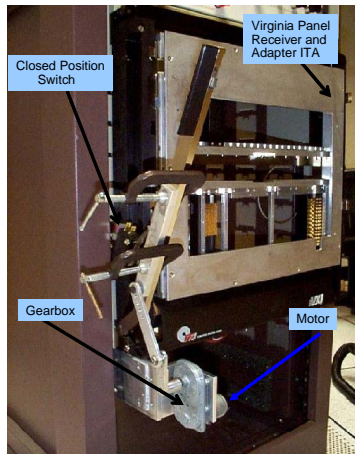

A study with 25,000 cycles of a PWB ITA demonstrated the robustness of the design. Figure 7 is a picture of the cycle test mechanism.

The cycle test had very low and acceptable PWB gold pad wear. Performance verification during each cycle of resistance and S parameters yielded no failures. Figure 8 has a graph of the resistance test results.

Figure 8

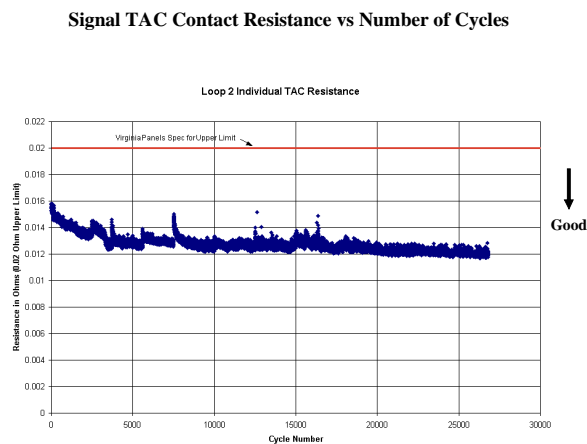

Adapter-to-Adapter Mechanical

The adapter-to-adapter construction consists of a frame, a legacy ATS-182 compatible receiver, a TAC pin block, and a PWB. See Figure 8.

Figure 8

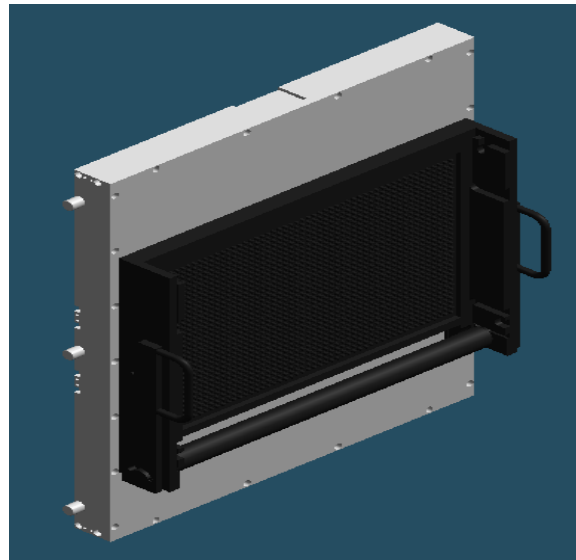

Inserted into the backside of the legacy receiver paddle-contact is an insert with a flat surface can be seen in Figure 9. The flat surface of the insert makes contact with a TAC pin which a dual pogo pin. The other end of the pogo pin makes contact with a gold pad on the PWB. An internal trace in the PWB translates the signal to a gold pad that is in alignment with a station receiver TAC pin. The weight of the adapter to adapter is approximately 40 pounds.

Figure 9

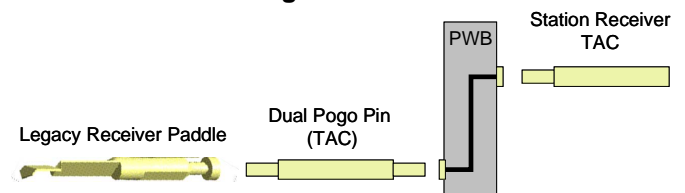
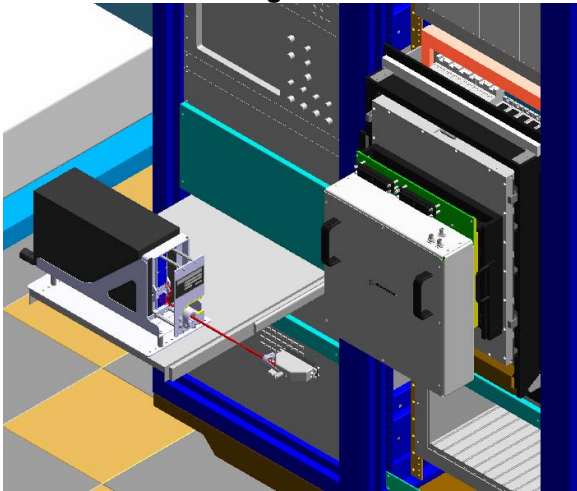

Figure 10



The adapter-to-adapter mates with the BCTS station receiver similar to any other ITA. See Figure 10. The legacy ATS-182 ITA mates with the adapter to adapter, which in turn connects to the UUT (Unit Under Test).

Adapter to Adapter PWB

Full support of the legacy ITAs requires emulation of not only the signal path connections, but also the signal path characteristics. Documentation of signal paths in the ATS-182 for resistance and capacitance values created requirements for the BCTS.

Discrete relays in the ATS-182 had very low resistance values. The relay boards had large unprotected trace widths. The location of the boards directly behind the legacy receiver contributed to the very low resistance values.

The matrix switch wiring contained several feet of wire, and had considerably higher resistance values.

In the new design, switching density increased considerably over the ATS-182 switching. Most of the newer switches had shielded paths, and because of the density, much smaller trace widths.

Utilization of a PWB over wiring has several advantages. The most significant and important advantage is the reduction of the variability from station to station. In an ATS with long cable lengths, the inconsistent routing of these cables from station to station causes variability between

the stations. Variation in the placement of cables creates changes in the real components (inductance and capacitance) of the signal paths. This in turn causes changes in crosstalk from station to station.

Conversely, a PWB maintains a consistent pattern. Trace paths from build to build do not change location in the PWB.

A PWB for a receiver coupled with the shorter and consistent cabling discussed earlier has a great impact on improvement of signal performance through out the design.

Because of the high trace density, signal trace placement distance decreases. Maintaining high quality signal path-performance requires careful attention to trace routing. Use of strip line technology is mandatory.

The adapter-to-adapter PWB was designed as a 30-layer PWB with an overall thickness of ¼ inch, which allowed routing of the legacy pads to the new ATS pads. The ¼ inch was required for both pressure from the pogo pin technology and support of large number of protected traces.

Because of the large number of protected traces, layout of the new receiver switching relative to the legacy receiver is important to the design. Maintaining paths from point to point through a single layer improves performance. Path layout was a consideration in selection of relays

Identification of specific signal path types from fifty-ohm strip line to unprotected signals allowed cross-referencing signal path types with required trace paths. This allowed for a consistent and comprehensive design.

Following are several signal path types examples:

- 100 Ohm Signal path Impedance between signals = 100 Ohms

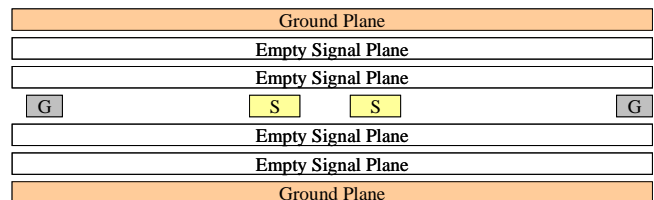

Note G = Guard S = Signal Path

- DMM Signal path controlled for noise, and wide traces for low resistance and uncontrolled impedance.

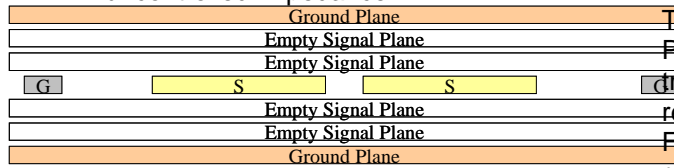

- AC power supply uncontrolled impedance, low resistance, guarded well.

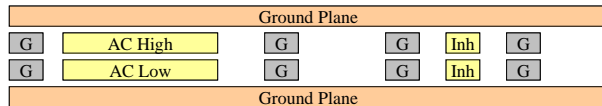

- Guarded signal paths for high density protected switching, uncontrolled impedance

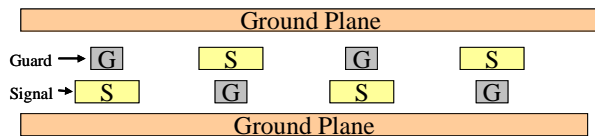

- Fifty-ohm strip line Impedance controlled paths with isolation controlled by distance. This pattern was required as a compromise to achieve trace density.

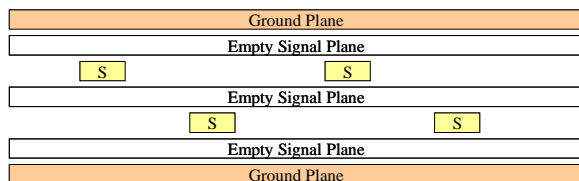

- High current DC supplies with high and low together for current coupling. Very wide traces.

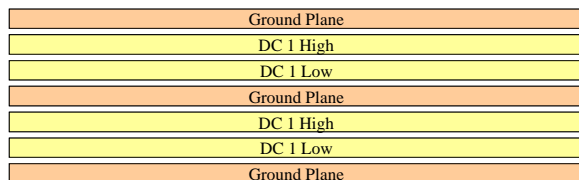

During the design process, tools calculated resistance, impedance, crosstalk, and capacitance of each trace type. An approximate length for the each trace type identified the total parametric for several of the traces. Using these

values along with identified path resistance for each switch allowed comprehensive results.

These values along with the information from the PWB design tools determined values for each trace. These calculated compared with the requirements identified areas of concern. Following the first PWB build, trace measurement results compared to the design measured values, and the requirements again identified areas of concern. Best-fit philosophy identified trace improvements.

Using data early in the process, allowed determination that the 1 by 8 relays had excessive path resistance. The relays used implemented dual path. Using both paths brought resistance values closer to requirements.

Due to the complexity and thickness of the PWB it was difficult to find a fabrication houses that had the capability to layout and build these boards. Significant research went into qualifying a supplier that had this capability. Initial PWB boards had significant VIA plating problems. A second vendor resulted in much better performance.

A comprehensive analysis of the first PWB identified several problem areas. Path resistance of several of the traces was higher then expected. This was due to a misunderstanding of the output of the PWB design tool. Misalignment of pads to the receiver was caused by misplacing an alignment pin with the receiver. Rectification for these discrepancies occurred on the second version.

Other issues included finding components that could be mounted on a 1/4 inch PWB. The order of preference for parts was first surface mount parts, followed by parts with leaded length greater then 1/4 inch, followed by the last resort of leaded parts shorter then 1/4 inch.

Cutting traces on the board interior was very difficult. Fifteen layers down in a thirty-layer board is next to impossible.

A second DMM added to the ATS-182 in its design evolution resulted in two DMMS being available at the legacy receiver. The BCTS supported only one DMM. To compensate, relays placed in the adapter-to-adapter allowed switching of the DMM to the correct location on the adapter. The DMM signal path layout along with very high quality relays solved this requirement.

DTU Adapter to Adapter

The DTU adapter followed the same evolutionary process as the receiver adapter to adapter, utilizing signal path concepts from the former design process. The adapter replaced the mechanical adapter on the front of the ATS-182 DTU, and a corresponding ITA used on the legacy receiver.

The mechanical adaptation required a great amount of ingenuity on the part of the packaging engineers. Implementation of several factory use identified requirements into the design resulted in a comprehensive and quality solution.

ITA Maintenance Tip

One other note on the pogo pin technology. Vacuuming of both the receiver and adapters reduced misconnects considerably. Application of the vacuum process to the BCTS resulted in the similar receiver to ITA contact performance increase.

INSTRUMENT SELECTION PROCESS

Best Fit

Instrument selection for the BCTS involved synthesizing requirements from existing ATS-182 instruments and ATS-195 Unit Under Test (UUT).

Excluded from the ATS-182 instrument list for this version of the BCTS was the FLUKE 9250 microprocessor emulator.

Excluded from the ATS-195 UUT tests for rehost were RF and video UUTs.

The instrument selection process used best fit from existing COTS instrumentation.

This involved finding COTS instruments meeting the requirements. Best-fit instruments not meeting ATS-182 instrument requirements resulted in a search of ATS-182 tests for specific requirements not met by the best-fit instrument. This process was very labor intensive. Where COTS instrumentation was not available, customized instrumentation was the next source of instrumentation.

Selection of customized instrumentation focused on instrument houses with a focus on the required technology, along with the ability to create focused instrumentation.

Following selection of instrumentation, development of ATS-182 BASIC drivers occurred.

During the integration process, problems with existing instruments were uncovered. Discussion of instrument issues occurs in the following paragraphs.

INSTRUMENT INTEGRATION ISSUES

LVDTS

Synthesized requirements for the ATS-182 existing LVDTS came from the instrument documentation. Using these requirements, procurement of an instrument meeting these specifications occurred.

During integration, it became apparent that the new instrument was inadequate. Subsequent investigation revealed that ATS-182 tests were using the transformers beyond rated specifications, resulting in linearity problems at lower impedances.

A new instrument meeting the capability of the original instrument versus the specification allowed proper testing of legacy ATS-182 UUT.

Arbitrary Waveform Generator

Minimizing the instrument count, the Arbitrary Waveform Generator replaced the function generator in the ATS-182. Following is a short discussion of some of the issues.

The original ATS-182 function generator contained an internal switched termination resistor. A switched resistor controlled by the system drivers was replicated on each adapter to adapter.

Frequency synthesis between the steps in the sample frequency required rewriting the waveform memory.

Voltages below 0.4 volts resulted in accuracy issues. A resistor divider on the adapter to adapter helped this issue.

Digital Test Unit Subsystem

The DTU on the ATS-182 output impedance was different from the instrument selected for the BCTS. A designed circuit placed between the digital subsystem and the BCTS receiver solved this issue.

Switching

Replication of the ATS-182 matrix switch resulted in several issues. The legacy matrix had unique switching requirements to replicate in the adapter to adapter. Several rules written to mimic these requirements were implemented into the driver.

Resistance in the ATS-182 for discrete switches was very low. Throughout the design, consideration for this issue was at the forefront, but was never completely rectified. As a result, two wire measurements of low resistance on some TPS steps failed, and had to be rectified in the TPS.

Virtual Instruments

The ATS-195 test used an audio analyzer. To minimize instrument selection, an analog virtual instrument was selected to replace this instrument. Defining traceable requirements was very difficult because the virtual instrument had an overall accuracy specification, but its supporting specifications were not available. The result was a very difficult traceable specification to document

SUMMARY

Overall, the hardware integration of the BCTS has gone well.

There is no magic that will solve all problems, but this design synthesis has allowed a solution that integrates well.